

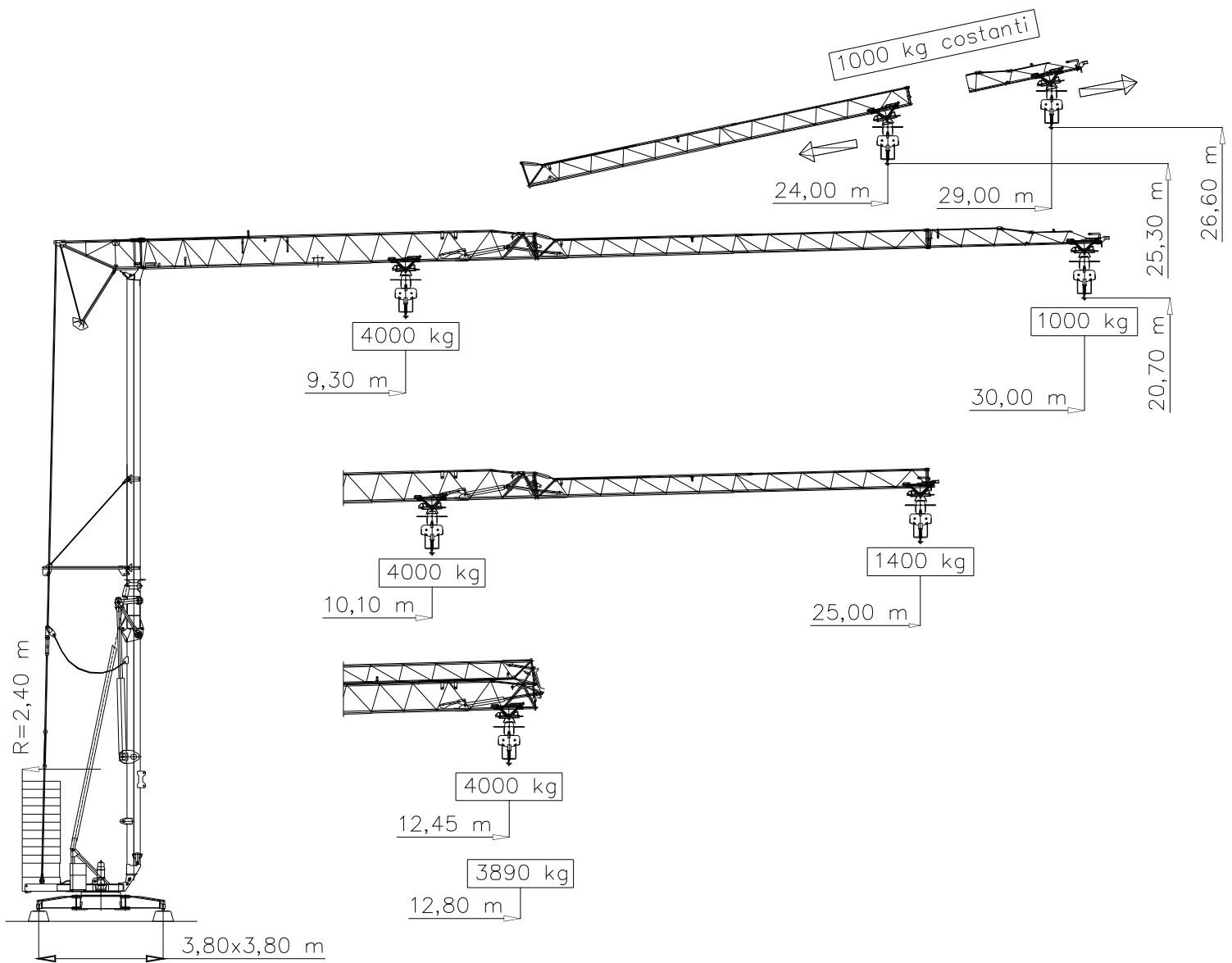

**MaSol** S.R.L.®  
MACCHINE SOLLEVAMENTO

**H.S. 30.10**



**MA.SOL. s.r.l.**

Stabilimento ed uffici: via Buonarroti 26/7 26024 Paderno Ponchielli (CR) Italy - Mecc. Estero CR 010071  
Tel.: +39 0374 367098 - Fax: +39 0374 367128 - E-mail: info@masol.it - Web: www.masol.it

# СХЕМЫ ГРУЗ - Curbe de Sarcina - Load curves - Curve di carico

30 m													m
		9,30	10	12	14	16	16,70	18	20	22	24	26	
25 m													m
		→ 10,10	12	14	16	18,24	20	22	24	25	kg		
13 m													m
		→ → 12,45	12,80	kg									
		→ → 4000	3890	kg									

наклонённой стрелой - Brat Inclinat  
Luffing jib - Braccio impennato

**1000 kg - cost.**

## Механизмы - Mecanisme Mechanisms - Meccanismi

			m/min	kg	CV-PS hp	kw
ПОДЪЁМ Ridicare Hoisting Sollevamento			6	2000	3	2,2
			24	2000	12	8,8
			48	1300	14	10,3
			3	4000	3	2,2
			12	4000	12	8,8
			24	2600	14	10,3
ПЕРЕМЕЩЕНИЕ ТЕЛЕЖКИ - Distributie Caruciorului Trolleying - Carrello			20/40		1,5/3	1,1/2,2
ВРАЩЕНИЕ - Rotatie Slewing - Rotazione			0,2-0,95 rpm - g/min		3,5 daNm	
ПЕРЕМЕЩЕНИЕ КРАНА - Deplasare Travelling - Traslazione			30		1,5x $n^{\circ}2$	1,1x $n^{\circ}2$
ТРЕБУЕМАЯ МОЩНОСТЬ Putere Electrica Necesara Necessary electric power Potenza elettrica necessaria	380 V 50 hz 	электроэнергии - Putere Main supply - Potenza		20 kw		
		ГЕНЕРАТОР ЭНЕРГИИ Grup Electrogen - Generator set Gruppo elettrogeno		Спросите нас Consultati-ne - Consult us Consultarci		

Вес крана без осей - Greutatea Macaralei fara Tren de rulare  
Dead weight without transport axles - Peso della gru senza assali

10700 kg

Вес балластов - Masa Contragreutatii - Ballast weight - Peso zavorra rotante

19300 kg

# РЕАКЦИЯ - Reactii in reazame - Reactions - Reazioni

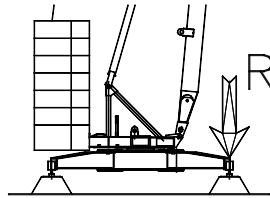

**R ● 18900 daN ■ 10900 daN**

● в эксплуатации	● In Functiune	● In service	● In servizio
■ вышли из строя	■ Oprit	■ Out of service	■ Fuori servizio

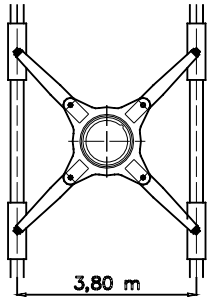

переход прямой  
Versiune cu cale de rulare paralela  
Straight track version  
Versione traslazione diritta

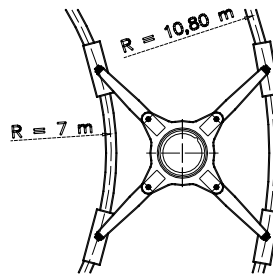

перевод кривой  
Versiune cu cale de rulare radiala  
Curved track version  
Versione traslazione curva

# ПОЛОЖЕНИЯ БУКСИРОВКИ - Modalitate de Transport Kind of transport - Soluzione di traino

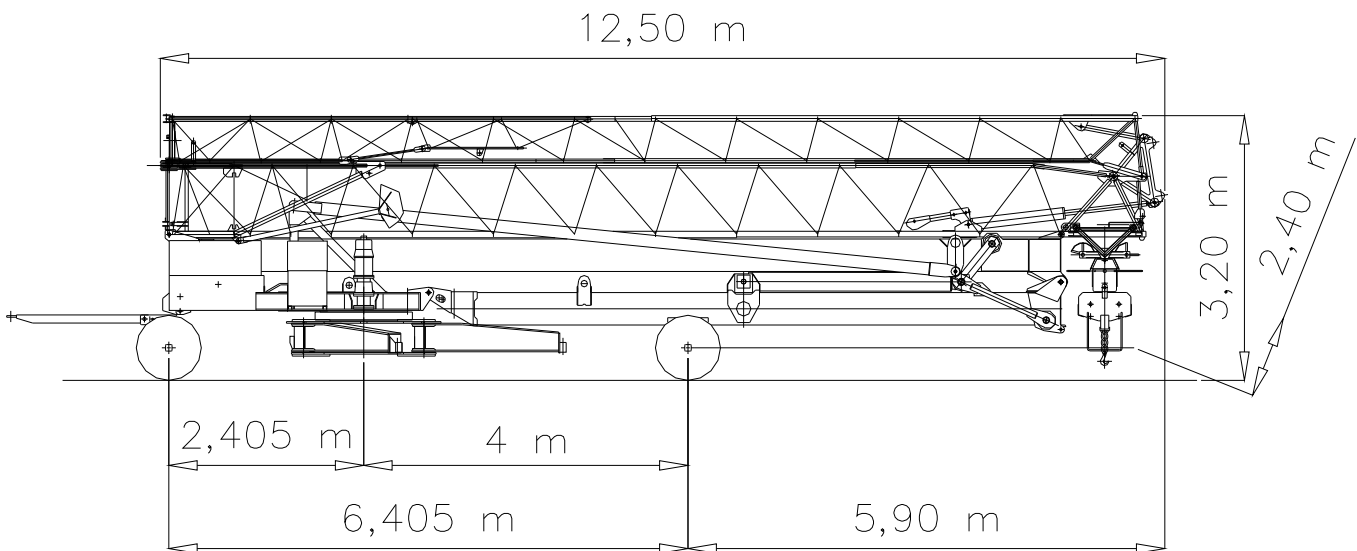

# МОНТАЖ - Montaj - Erection - Montaggio

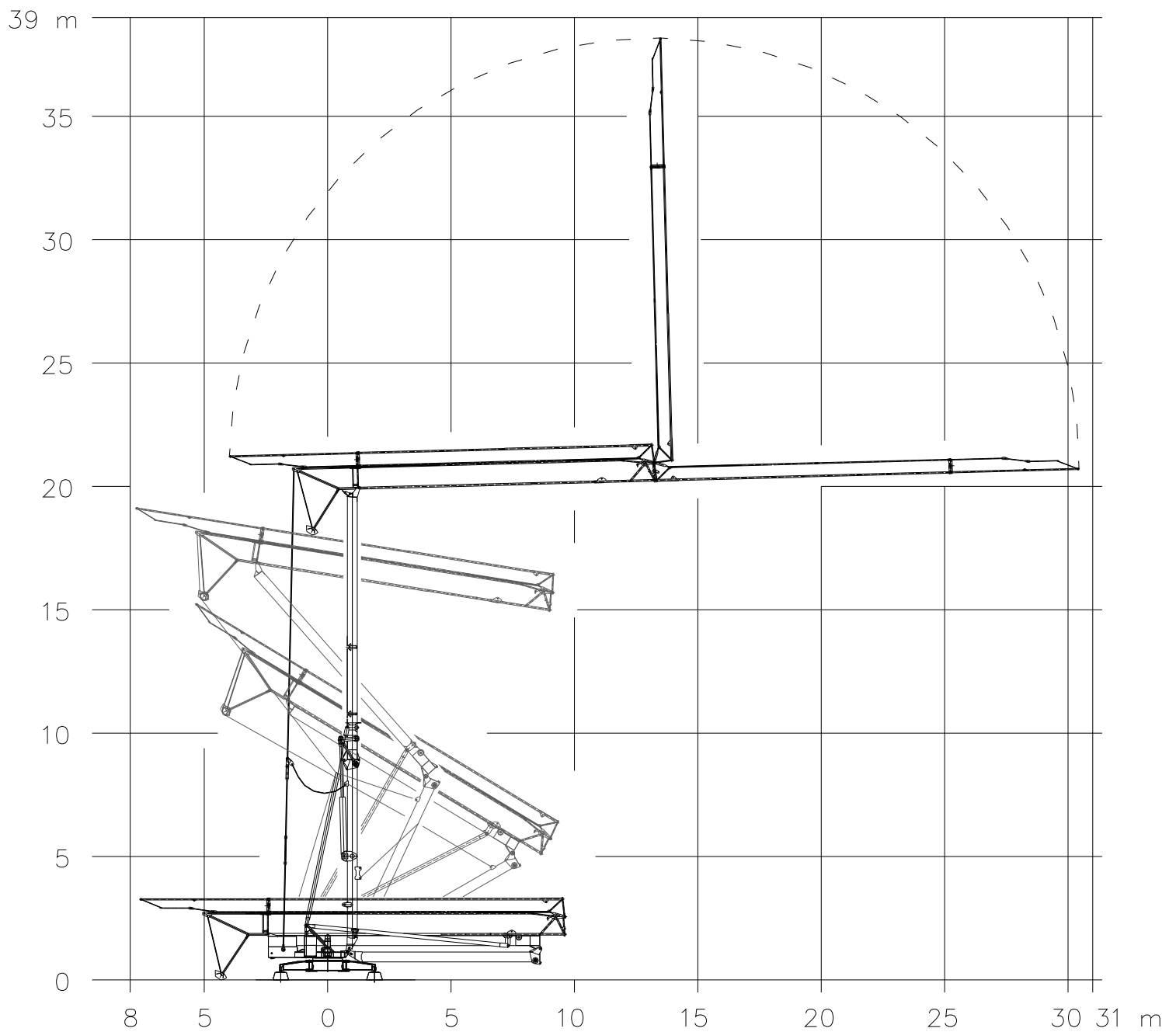

**MA.SOL. s.r.l.**  
Stabilimento ed uffici:  
via Buonarroti 26/7  
26024 Paderno Ponchielli (CR) Italy  
Mecc. Estero CR 010071  
Tel. +39 0374 367098  
Fax +39 0374 367128  
E-mail: info@masol.it  
Web: www.masol.it

