

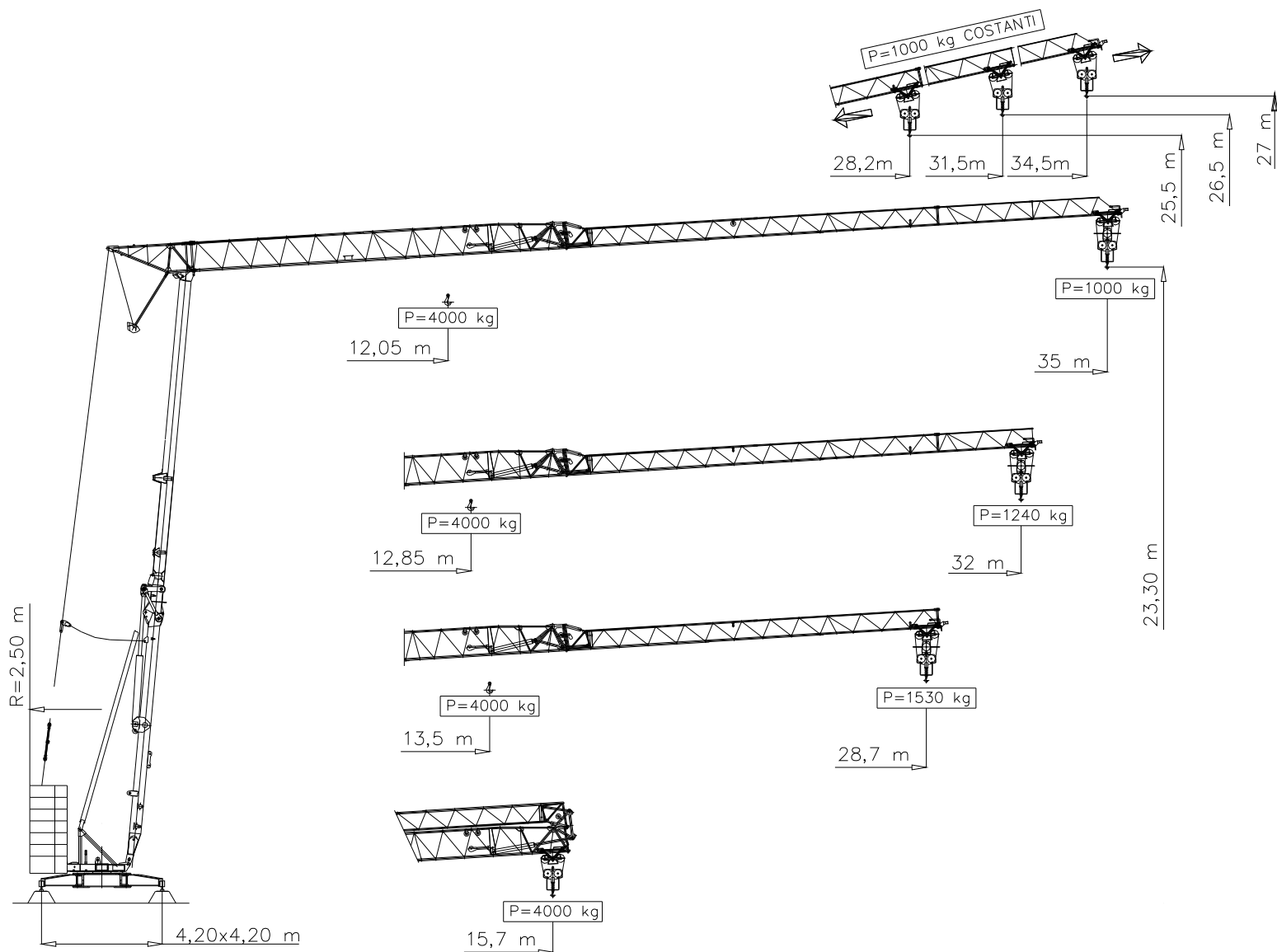

MaSol S.R.L.[®]
MACCHINE SOLLEVAMENTO

H.S. 35.10



MA.SOL. s.r.l.

Stabilimento ed uffici: via Buonarroti 26/7 26024 Paderno Ponchielli (CR) Italy - Mecc. Estero CR 010071
Tel.: +39 0374 367098 - Fax: +39 0374 367128 - E-mail: info@masol.it - Web: www.masol.it

СХЕМЫ ГРУЗ - Curbe de Sarcina - Load curves - Curve di carico

35 m		3 circles				2 circles								m	
		12,05	14	16	18	20,4	22	24	26	28	30	32	34		35
		4000	3240	2700	2300	2000	1815	1620	1465	1330	1220	1120	1035	1000	kg

32 m		3 circles				2 circles							m
		12,85	14	16	18	20	21,95	24	26	28	30	32	
		4000	3550	2960	2530	2200	2000	1785	1610	1465	1345	1240	kg

28,7 m		3 circles				2 circles						m
		13,5	14	16	18	20	22	23,21	24	26	28,7	
		4000	3815	3185	2720	2370	2090	2000	1910	1750	1530	kg

15,7 m		3 circles		2 circles		4000 kg - cost.	
		12,05	14	16	18		20,4
		4000	3240	2700	2300	2000	1815

наклонённой стрелой - Brat Inclinat
Luffing jib - Braccio impennato

1000 kg - cost.

Механизмы - Mecanisme Mechanisms - Meccanismi

			m/min	kg	CV-PS hp	kw
ПОДЪЁМ Ridicare Hoisting Sollevamento			6	2000	3	2,2
			24	2000	12	8,8
			48	1300	14	10,3
			3	4000	3	2,2
			12	4000	12	8,8
			24	2600	14	10,3
ПЕРЕМЕЩЕНИЕ ТЕЛЕЖКИ - Distributie Caruciorului Trolleying - Carrello			20/40		1,5/3	1,1/2,2
ВРАЩЕНИЕ - Rotatie Slewing - Rotazione			0,2-1,1 rpm - g/min		3,5 daNm	
ПЕРЕМЕЩЕНИЕ КРАНА - Deplasare Travelling - Traslazione			30		1,5x $n^{\circ}2$	1,1x $n^{\circ}2$
ТРЕБУЕМАЯ МОЩНОСТЬ Putere Electrica Necesara Necessary electric power Potenza elettrica necessaria	380 V 50 hz 	электроэнергии - Putere Main supply - Potenza		20 kw		
		ГЕНЕРАТОР ЭНЕРГИИ Grup Electrogen - Generator set Gruppo elettrogeno		Спросите нас Consultati-ne - Consult us Consultarci		

Вес крана без осей - Greutatea Macaralei fara Tren de rulare
Dead weight without transport axles - Peso della gru senza assali

13800 kg

Вес балластов - Masa Contragreutatii - Ballast weight - Peso zavorra rotante

25000 kg

РЕАКЦИЯ - Reactii in reazame - Reactions - Reazioni

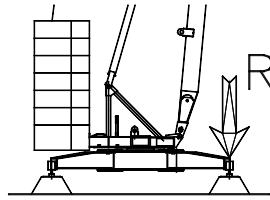

R ● 23900 daN ■ 16100 daN

● в эксплуатации	● In Functiune	● In service	● In servizio
■ вышли из строя	■ Oprit	■ Out of service	■ Fuori servizio

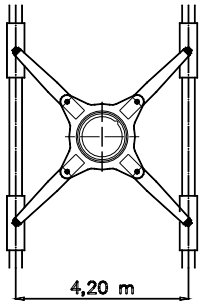

переход прямой
 Versiune cu cale de rulare paralela
 Straight track version
 Versiune traslazione diritta

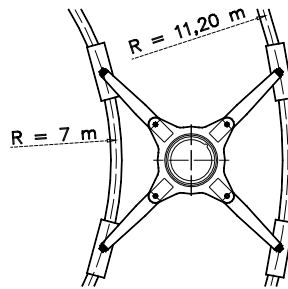

перевод кривой
 Versiune cu cale de rulare radiala
 Curved track version
 Versiune traslazione curva

ПОЛОЖЕНИЯ БУКСИРОВКИ - Modalitate de Transport Kind of transport - Soluzione di traino

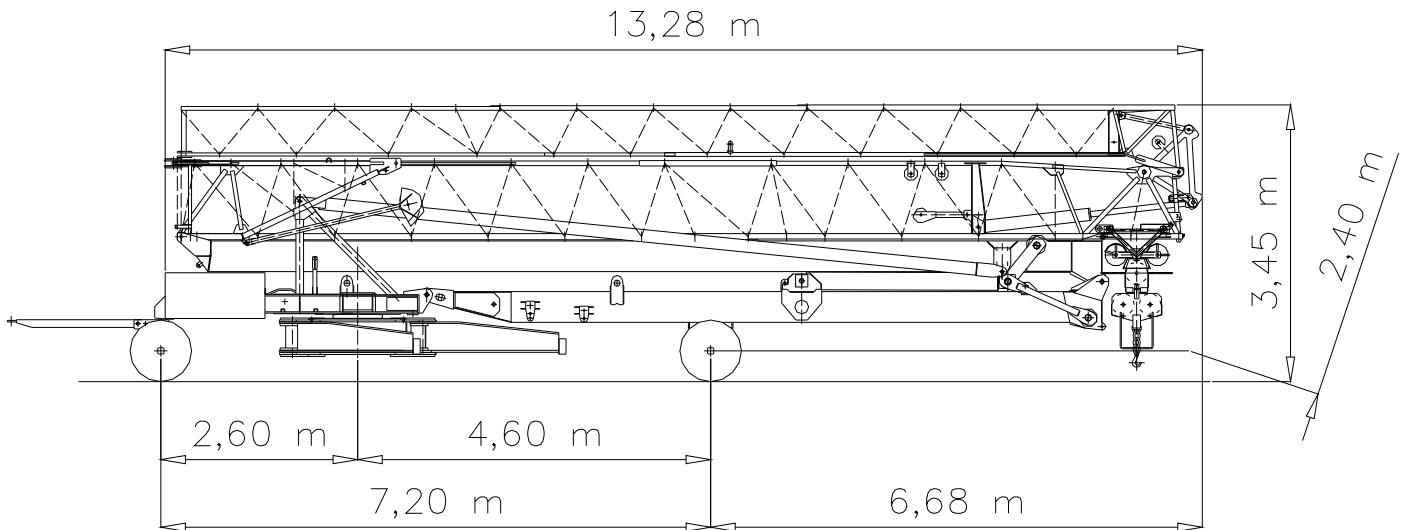

МОНТАЖ - Montaj - Erection - Montaggio

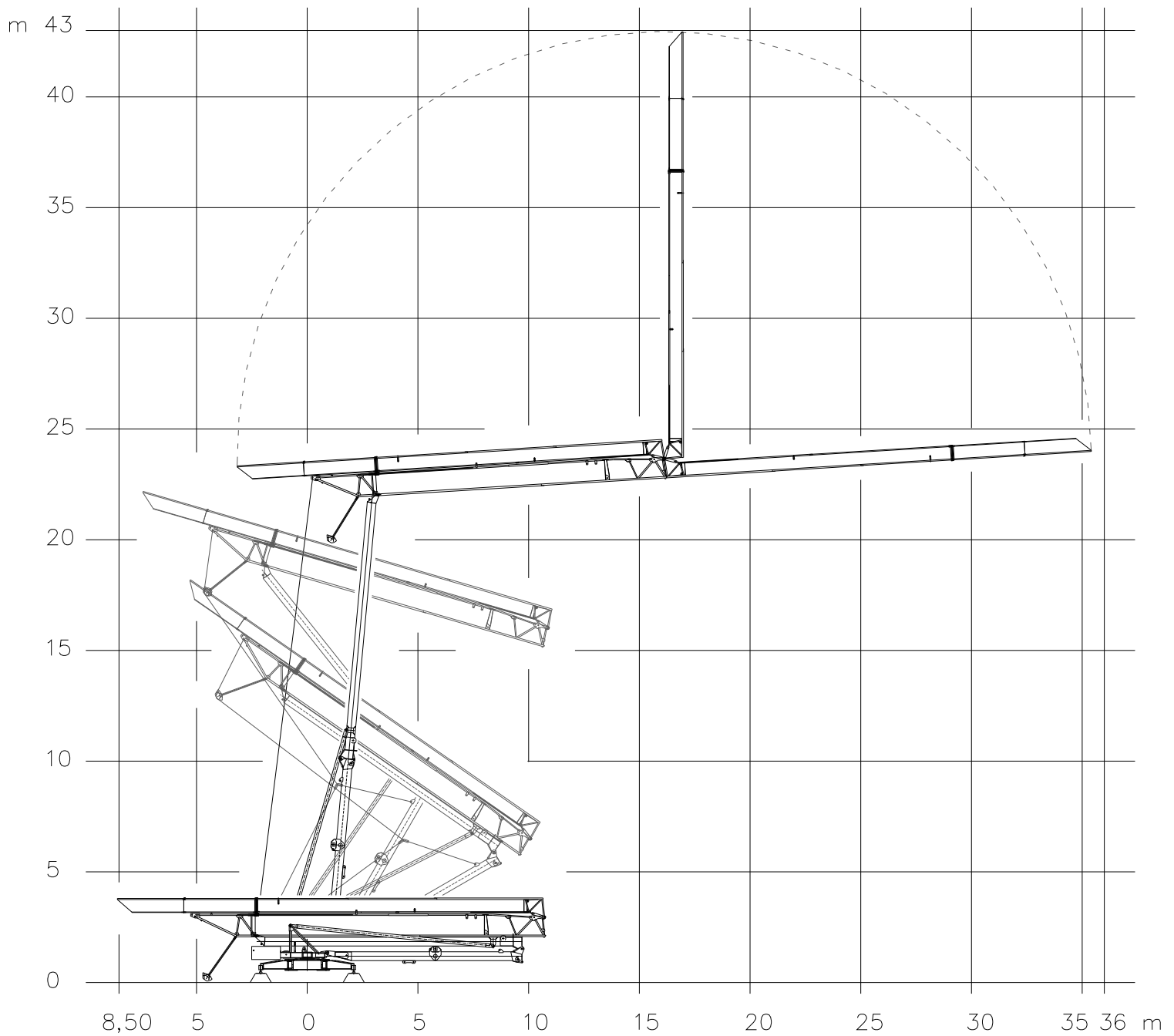

MA.SOL. s.r.l.
Stabilimento ed uffici:
via Buonarroti 26/7
26024 Paderno Ponchielli (CR) Italy
Mecc. Estero CR 010071
Tel. +39 0374 367098
Fax +39 0374 367128
E-mail: info@masol.it
Web: www.masol.it

